

# INSTRUCTIONS FOR USE

## BED XPRIM III (XN1)

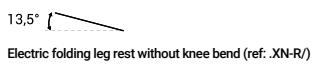
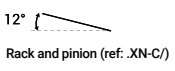
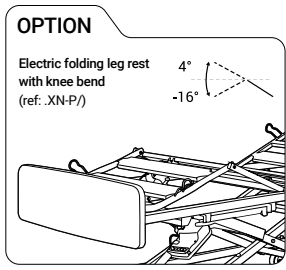
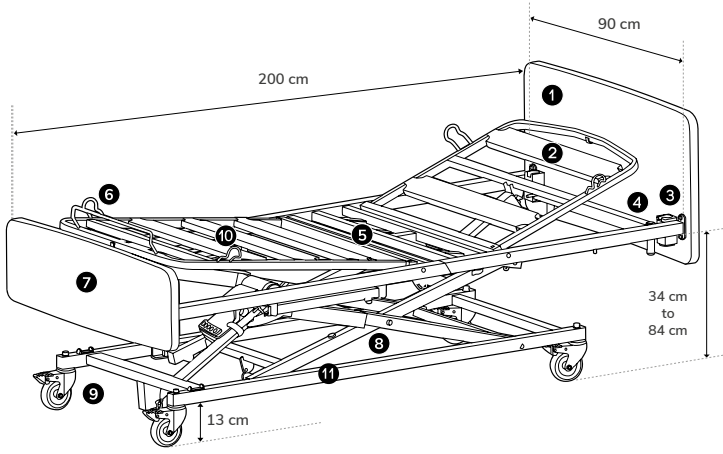

**Weight of the device**

		kg
	(C/)	63,4
	(P/R/)	67,5

- 1 Head panel,
- 2 Back rest,
- 3 Angled lifting pole slots,
- 4 Stand slots,
- 5 Bed base,
- 6 Mattress retainer,
- 7 Foot panel,
- 8 Frame (base and cross braces),
- 9 Wheels Ø10 cm,
- 10 Rack and pinion,
- 11 Base.

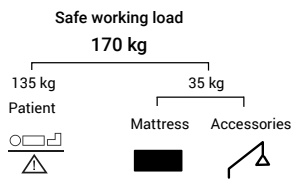

Photo/design non contractual

580136 English

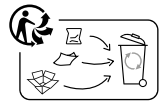

## 1. INDICATIONS

### Device Intended Use

Compensation for disability. Prevention.

### Indications

The X'PRIM III bed is suitable for adults to compensate for substantial, lasting or permanent impairment of one or more physical functions (locomotor deficiency of the lower and/or upper limbs) or certain disabling health problems, and to prevent or reduce the repercussions of prolonged immobilization. Help with care and activities of daily living.

### Target patient and user group

Individuals with a height greater than or equal to 146 cm, a weight greater than or equal to 40 kg, and a BMI greater than or equal to 17.

### Contra-indications

- To be determined by the prescribing doctor.
- Patient's weight and height different than those specified in the conditions of use.



### Report undesirable side-effects

Inform the competent authority if you consider or have reason to believe that the device presents a serious risk or that it is a fake product.

## 2. COMPOSITION OF THE MEDICAL DEVICE

Frame, articulated and variable height bed base, head and foot boards.

### Accessories (option):

Serum rod, remote control supports, bedpan and urinal, wall stop, support handle, wooden rails, SAM Mobility Assistance System, bed base extension, corner or free-standing bracket, transport kit, ¾ metal rails, aluminium half rails, bedskirt, long sides.

Incompatible accessories, panels and mattresses can create hazards. Only accessories and panels distributed by WINNCARE France guarantee compatibility with our products and the conformity of the whole (CE marking).

## 3. CLINICAL BENEFIT, PERFORMANCE

### Expected clinical benefits

Preservation of the patient's state of health, mobility, activity and transfers. Reduction of the repercussions of the immobilisation syndrome. Protection of the health and safety of users and others.

### Medical device performance

#### For patients:

- Preserves or improves the patient's physical and/or psychological state (back rest, leg rest flat),
- Acts as a fixed walking or mobilization aid (panels, SAM Mobility Assistance System - optional),
- Helps prevent pressure ulcers (back rest 30° and/or Fowler or semi-Fowler positions),
- Protection of patients and/or carers (barriers if prescribed for medical purposes),
- Mattress stability (lateral stop).

#### For healthcare professionals and/or caregivers

- Helps with the administration of care (back rest, leg rest, in the flat position),
- Easy access to head and foot for specific care (removable bed panels)
- Ergonomics and transfer assistance (variable height).

## 4. USAGE INSTRUCTIONS

### 4.1 User training and qualification

User training must be given by people trained and qualified in the use of the bed and accessories, cleaning and disinfection procedures and products.

### 4.2 Operating the device

Run a series of no-load tests to familiarise yourself with the bed's functions.

#### Bed braking

##### Centralised braking (option A)

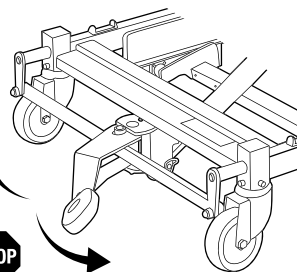

##### Separate braking

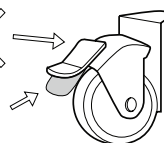

Make sure the wheels are locked when trying to move the bed. Failure to comply with this instruction may result in the patient or other person falling when using the bed for support.

### Fitting the "Easy Move" panels

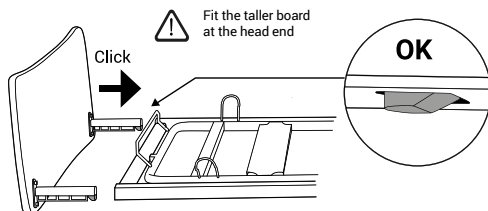

### Removing the panels

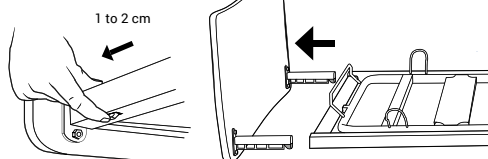

## Emergency release of the back rest (Cardio Pulmonary Resuscitation = CPR) (option -B)



Activate one of two release handles on the back rest while lowering.

If the handle is released the back rest will stop moving.

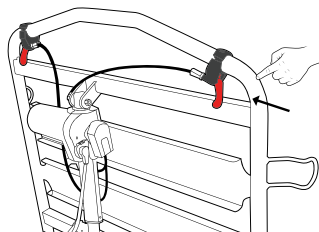

## Flattening of the back rest without CPR in the event of a power cut

Version of back rest with no CPR handle

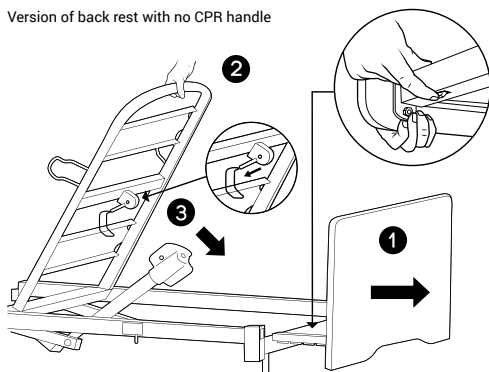

In the event of malfunction, power cut or to flatten the back rest (recommendation: handling by two caregivers).

- Dismantle the headboard ① by pressing the "Easymove"™ systems under the long side panels.
- Stand at the head of the bed and take hold of the back rest ② with one hand. Push or lift the back rest to compensate for the pressure exerted by the patient and unhook the safety pin ③ by the connecting with the other hand. The back rest jack will then pivot downwards.
- Accompany the descent of the back rest.

## Leg rest

Rack and pinion or electric folding leg rest (optional) with or without position memory.

## Barriers and SAM Mobility Assistance System

See bed barrier instructions for use and Mobility Assistance Systems available on the WINNCARE website ([www.winnicare.com](http://www.winnicare.com)).

## 4.3 Cleaning and disinfection

Consult the technical manual.

## 4.4 Maintenance

Annual preventive maintenance of the bed and its accessories must be carried out at least once a year by the operator or the supplying organisation. Only original parts and components distributed by WINNCARE France guarantee the safety and performance of the device. Repairs to electrical parts must be carried out exclusively by our supplier. The lifetime of the medical bed (base, cross braces and bed base) is eight (8) years, and that of the accessories and boards is five (5) years.

## 5. PRECAUTIONS FOR USE, WARNINGS

- The loads permitted (see bed characteristics) must be distributed evenly over surface of the bed base.
- Do not activate all the motors at the same time when the patient is in the bed.
- After each use and while care is being administered to the patient, the brakes must be activated. Put the bed in the low position while the patient is resting to reduce the height of falls by a confused or agitated person.
- When changing the position of the bed, make sure that no or parts of an object or person's body are caught between the bed and any of its components.
- Do not sit on the side of the back rest or leg rest if it is not in the flat position.
- In the case of a prolonged semi-seated position with a tilt of more than 50°, we recommend changing the position of the person in the bed every two (2) hours.
- When handling, take care not to catch the motor or remote control cables or allow knots to form in them. Keep cables well away from the ground and wheels.
- Use only original parts and components distributed by WINNCARE France to guarantee safety and maintain product conformity.
- The condition of the cables must be checked regularly. If the slightest deterioration is observed or any technical maintenance is required, the person responsible for bed maintenance must be contacted to carry out the repairs.
- Improper use of the bed may damage it or cause accidents to users (using the bed outdoors or transporting the patient in a vehicle, moving the bed on a slope with a gradient of more than 10°, sitting on the side of the back rest or leg rest section).
- A SAM Mobility Assistance System can be adapted to promote the person's independence.
- The power socket must remain accessible so that the bed can be disconnected quickly without pulling on the cable.
- The bed must not be used as a stretcher.
- Do not leave remote controls accessible to children.
- When changing the height or angle of any part of the bed, ensure that no object or part of the patient's or carer's body is between the bed, panels, accessories and the floor or between the panels and the base or between the cross-bars.
- (Re)assess the risk of patient entrapment in non-moving parts of the medical bed associated with bedrails and therapeutic mattresses (EN 60601-2-52 standard for adults).

## 6. SIDE EFFECTS

Patient fall. Immobilisation syndrome. Aggravation of fractures that have not been stabilised and/or procedural pain when the articulated parts of the bed base are moved.

Report to your doctor or nurse:

- ▷ Any abnormal event following skin contact with the surface of the materials from which the bed and its accessories are made.
- ▷ If the required measures concerning the use of the medical device cannot be followed.

All serious incidents which are related to the device must be notified to the manufacturer and the competent authority of the member state in which the user and/or patient resides.

## Residual risks

RISK	CONSEQUENCE	RECOMMENDATION
Trapping	Hands pinched	Move the leg rest or back rest using the handles or barriers at the specified points.
	Crushing of the body or an object	Check before operating the central brake pedal that the area between the pedal and the floor is free.

## 7. STORAGE, HANDLING, DISPOSAL

### Use

-10 °C      +38 °C

+14 °F      +100 °F

30%      75%

70kPA      106kPA

### Storage

-10 °C      +50 °C

+14 °F      +122 °F

30%      75%

70kPA      106kPA

### Disposal

Consult the manufacturer or distributor of the device.



Caution, see technical manual and/or instructions for use



Compliant with Regulation (EU) 2017/745 on medical devices



Separate collection at end of life



Warning, Selective sorting of electrical and electronic waste



Date of manufacture



Serial Number



Batch number



Patient Weight Range



Warning



Compatible with chlorine-based disinfection solution (5,000 ppm or 0.5% active chlorine)



Dry cleaning excluded, use of solvent-based remover excluded

## REMOTE CONTROLS

Backlit remote control with total magnetic locking

Remote control with selective mechanical locking



Back rest

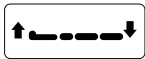

Variable height of the bed base



Leg rest



Chair position

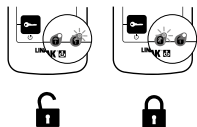
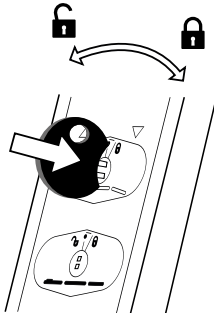
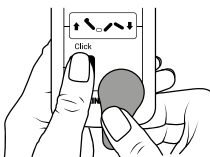

## WINN CARE

**CH REP**

Siotec AG, Sägestrasse 75, CH-3098 Köniz  
CHRN-AR-20001368

**UY REP**

TEGRAL Ltda. Av. Millán 5044, 12900 Montevideo,  
Departamento de Montevideo,  
Uruguay

**SA REP**

QETAF Medical EST. 3599 Princ Mohammed Bin. Abdulaziz  
ST., Saud Langawi Center, Al Andalus. Jeddah 23326  
Saudi Arabia

**IL REP**

כניסוק בע"מ, רחוב הבנאי 6 תוד השרון מיקוד 4531906 ישראל  
لمستورد : شركة خامينيك  
شارع هباني 6, هود هشارون الرمز البريدي 4531906

**UK REP**

Mangar International Limited (WINN CARE group)  
Presteigne Industrial Estate, Presteigne, LD8 2UF, Powys  
United Kingdom

**NZ REP**

Cubro Limited. 149 Taurikura Drive, Tauriko,  
Tauranga 3142  
New Zealand